

Yale®

By Columbus McKinnon



YALE PT SERIES B

RATCHET LEVER HOIST



FEATURES & BENEFITS

The Yale PT-B is the further development of our current PT hand lever hoist for everyday use, especially under extreme conditions. New enclosed handwheel design protects internal components from water and dirt for improved weatherproofing. New forked safety latch allows for better seating of the latch in the hook to better prevent disengagement or damage to the latch.

EASY TO USE

Due to optimized gearing and improved bearings in the housing cover a minimum effort is required to operate the hand lever.

LOAD PRESSURE BRAKE

Even today, the load pressure brake, based on the principle of Thomas Weston's patent of 1875, is still used in our manual hoists.

RUGGED DESIGN

Impact resistant stamped steel frame withstands repeated rigorous use.

RELIABLE LOAD GUIDANCE

The load chain runs in the load sheave and is secured against unintentional slipping by the closed chain guide.

NON SLIP RUBBER HANDLE GRIP

Comfortable rubber grip provides for extra protection against slippage.

IMPROVED SAFETY AND DURABILITY

The bolt on swivel hooks simplify the inspection process. Hooks are forged, allowing them to yield under overload without breaking. For added safety, the Yale PT-B now includes a forked latch that allows for better seating of the latch in the hook to prevent disengagement or damage to the latch.

EASY And SMOOTH FREE CHAINING

For quick take up and positioning of slack chain, even with one hand. Designed not to accidentally free chain while under load. Cast chain end stop allows the user to easily position the chain in free-chaining mode and prevents it from entering the liftwheel and jamming the hoist.

CORROSION PROTECTION

Chain guide, chain stripper and parts of the brake are zinc-plated or MKS-coated to ensure additional corrosion protection and durability when working in harsh environments.

OPTIONAL INTERNAL LOAD LIMITER

Allows handle to rotate freely when hoist is overloaded, preventing damage to the unit. Load limiter units feature a black hand wheel for quick and easy on-site identification.



Yale PT-B
CAPACITIES
800 – 6300 KG

Technical data							
Model	Art.-No.	Capacity kg	Number of chain falls	Chain dimensions d x p in mm/ design	Lift with one full lever turn mm	Handle pull at WLL daN	Weight at standard lift (1.5 m) kg
Yale PT-B 800	192111363	800	1	5.6 x 17.1 - T	24	20.5	5.5
Yale PT-B 1600	192111364	1600	1	7.1 x 21.2 - VH	19	31.2	9.4
Yale PT-B 3200	192111365	3200	1	9 x 27.2 - VH	16	33.3	16.3
Yale PT-B 6300	192111366	6300	2	9 x 27.2 - VH	8	33.7	30.5

Dimensions				
Model	Yale PT-B 800	Yale PT-B 1600	Yale PT-B 3200	Yale PT-B 6300
A min., mm	290	337	433	580
B, mm	21	27	36	53
C, mm	24	33	35	47
D, mm	14	19	24	34
E, mm	235	255	370	370
F, mm	120	138	177	244
G, mm	38	41	53	70
H, mm	82	97	124	174
J, mm	142	163	185	185
K, mm	52	65	83	83
L, mm	90	98	102	102



HANDWHEEL CLOSED

- Functional design against ingress of water and dirt
- With the enclosed design of the handwheel, the components of the brake remain unaffected by the incidence of humidity



NEW DESIGN HOOK & SAFETY LATCH

- Improved safety and durability
- Preventing the safety latch from disengaging

HAND LEVER SHORTENED BY 30%

- Improves safe operation in confined spaces

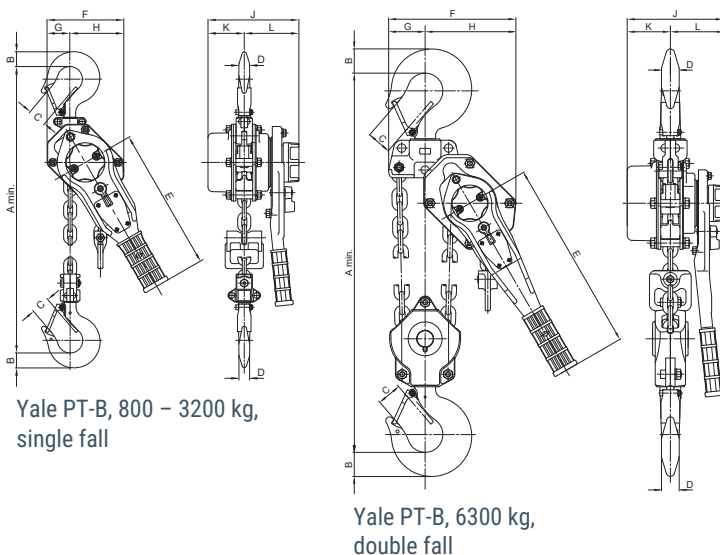

CMCO

INTELLIGENT MOTION

Columbus McKinnon

Columbus McKinnon has a history of over 150 years and is a world leader in lifting and intelligent motion control technology. The innovative portfolio of high-quality brands, including STAHL Crane-Systems, Magnetek, Pfaff-silberblau, Duff-Norton, Yale, Dorner, CM, montratec and Garvey addresses the needs of our customers by enhancing safety and promoting growth and efficiency. Experience, expertise and innovation combined with a deep understanding of user needs are the formula for success that has long underpinned our portfolio of hoists, material handling equipment and lifting accessories. Columbus McKinnon is a global organization headquartered in Charlotte, USA (North Carolina). Its global presence includes offices and manufacturing facilities in North America, Latin America, Europe, Africa and Asia.



www.cmco.com

STAHL
Crane Systems



MAGNETEK

PAFF
silberblau



Duff-Norton

Yale

DORNER

CM

montratec

GARVEY