

Screw jacks

Couplings and connecting shafts

Features and processing

Configuration to suit requirements: screw jacks from Columbus McKinnon Engineered Products can be assembled modularly to suit the application.

Each element meets the highest quality standards. This also applies to the couplings and connecting shafts. The torsionally flexible couplings protect the worm gear screw jacks, bevel gearboxes and motors by damping shocks and vibrations

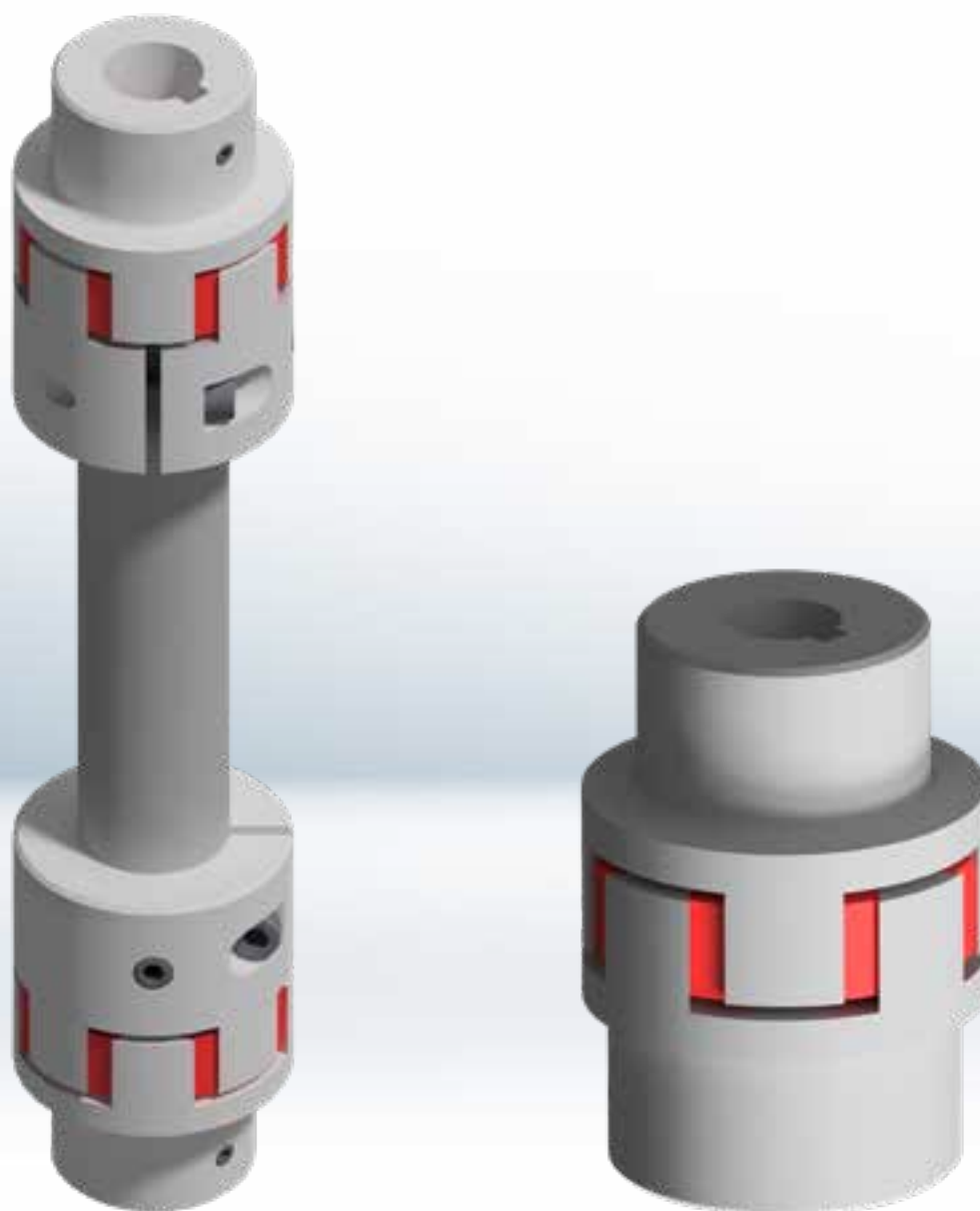

A



B



C

D

Couplings and connecting shafts

Flexible couplings

Features and processing

R series: the torsionally flexible couplings of the R series dampen vibrations and shocks and compensate axial, radial and angular displacements. They are therefore preferable to rigid couplings or shaft connections.

Technical information: R range

Size R	Nominal torque T_N [Nm]			Max. angular displacement [°]	Torsion angle at T_N [°]	Max. axial displacement [mm]	Max. radial displacement [mm]	Mass moments of inertia ¹⁾ J [kgm ²]	Material ²⁾	Weight ³⁾ [kg] Design	
	92° Shore	95° Shore	98° Shore							a/a	b/b
14	7	-	12	1,2	6,4	1	0,17	$5,60 \times 10^{-6}$	AL	0,14	0,14
19/24	10	-	17	1,2		1,2	0,2	$1,03 \times 10^{-6}$	AL or St	0,32	0,36
24/28	35	-	60	0,9	3,2	1,4	0,22	$4,30 \times 10^{-4}$		0,6	0,72
28/38	95	-	160	0,9		1,5	0,25	$9,80 \times 10^{-4}$		0,97	1,33
38/45	190	-	325	1,0		1,8	0,28	$96,5 \times 10^{-4}$		2,08	2,46
42/55	265	-	450	1,0		2	0,32	$0,35 \times 10^{-2}$		3,21	3,93
48/60	310	-	525	1,1		2,1	0,36	$1,06 \times 10^{-2}$	GG or St	4,41	5,19
55/70	410	-	685	1,1	3,2	2,2	0,38	$2,03 \times 10^{-2}$		6,64	8,1
65/75	625	940	-	1,2		2,6	0,42	$3,80 \times 10^{-2}$		10,13	11,65
75/90	1280	1920	-	1,2		3	0,48	$8,20 \times 10^{-2}$		16,03	19,43
90/100	2400	3600	-	1,2		3,4	0,5	$23,8 \times 10^{-2}$		27,5	31,7

¹⁾ Values for steel hubs b-b and max. finish bore without keyway. For aluminum, the value is reduced by a factor of approx. 3. See table on page 108.

²⁾ For use with hardened drive shafts is select coupling with material cast iron or steel (sizes R19/24 - R48/60 also in stainless steel 1.4571).

³⁾ Weight for material gray cast iron, for aluminum approx. 60 % less.

Color coding of the various flexible spiders:

- 92° Shore orange
- 95/98° Shore purple

Operating temperature:

- 92° Shore -40° to +90 °C
- 95/98° Shore -30° to +90 °C

Dimensioning:

The nominal torque (T_N) of the couplings – with **impact factor S⁴⁾** taken into account– must be at least equal to the system torque (T_{ANL}) to be transferred.

$$T_N \geq T_{ANL} \times S$$

⁴⁾ Impact factor S = 2 for use with three-phase motors

A



B



C

D

Couplings and connecting shafts

Technical drawings and dimensions

Technical drawings: R range

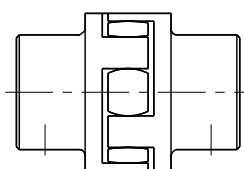
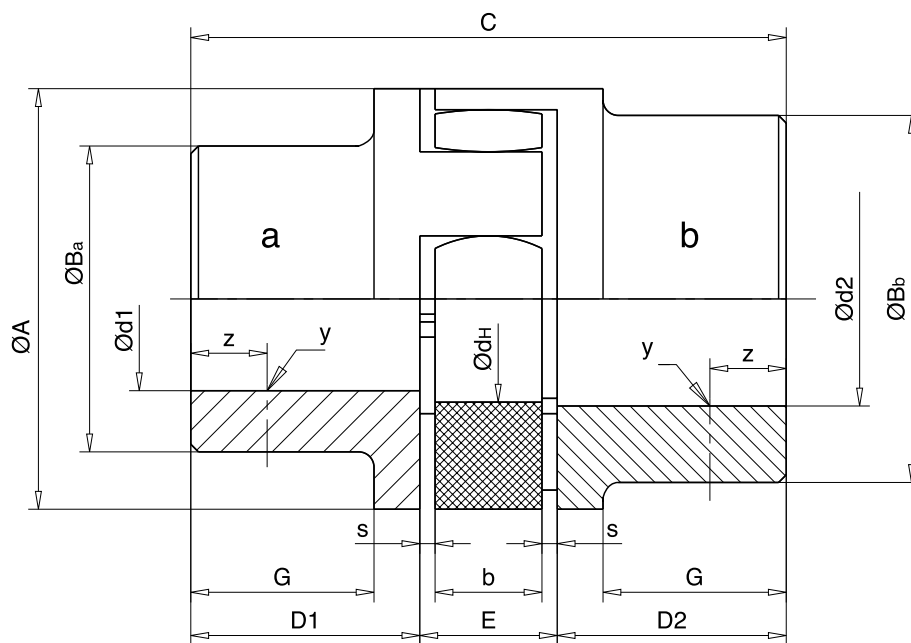

Design: aa

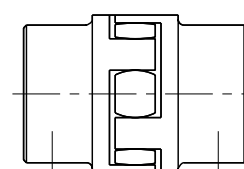

Design: bb

Dimensions: R range

Size R	Ready-drilled holes $\text{\O}dH7^{1)}$				$\text{\O}A$	$\text{\O}B_a$	$\text{\O}B_b$	C	D1 ²⁾ and D2 ²⁾	E	s	b	G	$\text{\O}d_H$	y	z
	Hub a $\text{\O}d1$		Hub b $\text{\O}d2$													
	min	max	min	max												
14	-	-	6	14	30	30	-	35	11	13	1,5	10	-	10	M4	~5
19/24	6	19	6	24	40	32	40	66	25	16	2	12	20	18	M5	10
24/28	8	24	8	28	55	40	48	78	30	18	2	14	24	27	M5	10
28/38	10	28	10	38	65	48	65	90	35	20	2,5	15	28	30	M8	15
38/45	12	38	38	45	80	66	77	114	45	24	3	18	37	38	M8	15
42/55	14	42	42	55	95	75	94	126	50	26	3	20	40	46	M8	20
48/60	15	48	48	60	105	85	102	140	56	28	3,5	21	45	51	M8	20
55/70	20	55	55	70	120	98	120	160	65	30	4	22	52	60	M10	20
65/75	22	65	65	75	135	115	135	185	75	35	4,5	26	61	68	M10	20
75/90	30	75	75	90	160	135	160	210	85	40	5	30	69	80	M10	25
90/100	40	90	90	100	200	160	180	245	100	45	5,5	34	81	100	M12	25

¹⁾ Feather key grooves are configured according to DIN 6885/1 standards

²⁾ Special hub lengths available on request

Couplings and connecting shafts

Flexible overload couplings

Features and processing

Flexible overload couplings limit the drive torque (lifting force) of the lifting system, thus protecting the mechanism from overloads and malfunctions in the event of the drive system becoming blocked.

MKR range: Torque is transferred via wear-resistant, oil-proof and temperature-protected friction linings, which are held in place by means of disc springs.

MKR (R = friction linings). Friction linings are also available in rust-free configuration for outdoor use.

Technical information: MKR range

Size	Torque limit for overload		Rotary speed n max. [min ⁻¹]	Weight pre-drilled [kg]
	Type MKR1 [Nm]	Type MKR2 [Nm]		
0	2 – 10	10 – 20	7000	1,3
01	6 – 30	30 – 60	6500	3,0
1	14 – 70	70 – 130	5600	3,2
2	26 – 130	130 – 250	4300	6,5
3	50 – 250	250 – 550	3300	10,1
4	110 – 550	550 – 1100	2700	19,5
5	140 – 700	700 – 1400	2200	23,4

Dimensioning:

The controlling torque of the overload coupling is factory-adjusted, with reference to starting torque T_A to 1.4 times the torque to be transferred (T_N).



Production Pfaff-silberblau: Worm gear screw jacks housing machining

A

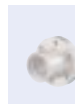

B



C



D

Couplings and connecting shafts

Flexible overload couplings

Technical drawings: MKR range

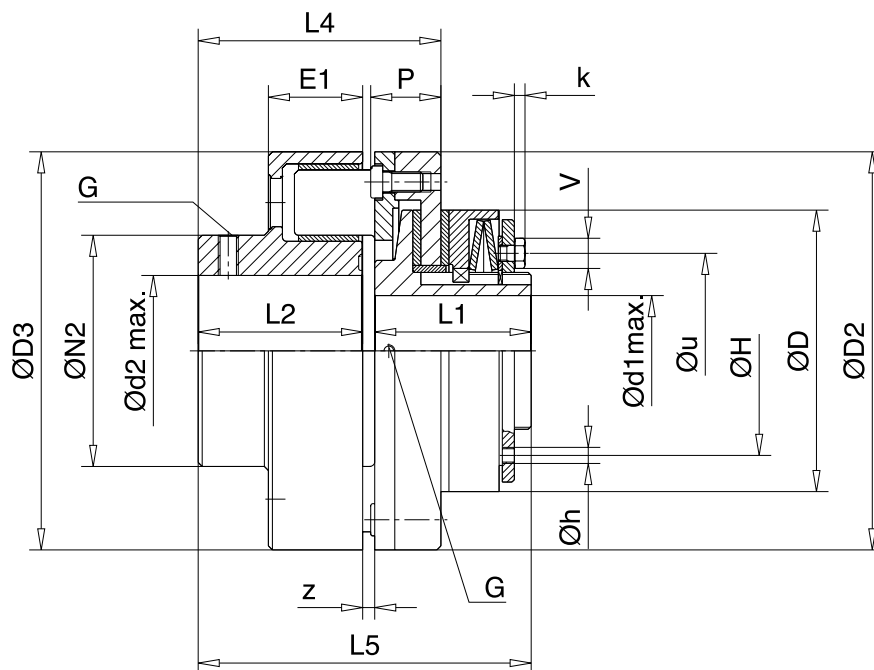

Dimensions: MKR range

Size	ØD	ØD3	ØD2	Ød ¹ min	Ød ¹ max	Ød ² min	Ød ² max	E1	G	H
0	45	80	80	7	20 ¹⁾	11	30	23	M4	37
01	58	110	110	12	22	11	48	40	M6	46
1	68	110	110	12	25	11	48	40	M6	50
2	88	140	140	15	35	13	60	42	M8	67
3	115	160	160	19	45	25	65	39	M10	84
4	140	198	198	25	55	30	75	47	M8	104
5	170	198	198	30	65	50	75	47	M8	125

Size	Øh	k	L1	L5	L4	P	L2	ØN2	z	Øu	V
0	3	5 ²⁾	33	66	48	15	30	45	3	37	2 ²⁾
01	5	5 ²⁾	45	91	68	22	40	86	3	46	2,5 ²⁾
1	5	5 ²⁾	52	96	69	23	42	86	3	50	3 ²⁾
2	6	3	57	119	93	33	55	100	3	67	10
3	6	5,5	68	136	112	35	60	108	4	84	13
4	7	5,5	78	165	122	35	82	115	6	97	13
5	8	5,5	92	179	127	40	82	115	6	109	13

¹⁾ Up to Ø19 groove according to DIN 6885-1, over Ø19 groove according to DIN 6885-3

²⁾ Countersunk screw with hexagon socket DIN 7991

A



B



C

D

Couplings and connecting shafts

Highly flexible connecting shafts

Features and processing

Highly flexible connecting shafts connect individual drive elements to form complete lifting systems with a central drive.

They dampen vibrations and shocks, compensate for axial, radial and angular displacements and can be used up to the critical speed without pillow blocks (see speed-length diagram).

The fitting of pillow blocks allows the shaft length L to be doubled or quadrupled. However, in a one-piece configuration, it is limited to a length of 6 m due to the standard lengths of tube normally available.

Four different versions are available for different speed ranges and requirements



Technical information: ZR range

Size ZR	Nominal torque $T_N^{1)}$ [Nm]	Locking screw		Max. angle displacement [°]	Axial displacement [mm]	Mass moments of inertia		Suitable pillow blocks	Weight	
		Starting torque ²⁾ [Nm]	M1			for 2 hubs [kgm ²]	for 1 m tube length [kgm ²]		for 2 hubs [kg]	for 1 m tube length [kg]
19/24	17	14	M6	0,9	1,2	$0,8278 \times 10^{-4}$	$0,932 \times 10^{-4}$	SN 505	0,3	1,3
24/28	30	14	M6	0,9	1,4	$8,830 \times 10^{-4}$	$4,414 \times 10^{-4}$	SN 507	1,5	2
28/38	70	35	M8	0,9	1,5	$20,05 \times 10^{-4}$	$7,431 \times 10^{-4}$	SN 508	2,7	3,1
38/45	130	35	M10	1,0	1,8	$20,15 \times 10^{-4}$	$11,59 \times 10^{-4}$	SN 509	3	3,6
42/55	150	69	M10	1,0	2	$47,86 \times 10^{-4}$	$17,07 \times 10^{-4}$	SN 510	5	4,1
48/60	245	120	M12	1,1	2,1	$74,68 \times 10^{-4}$	$24,06 \times 10^{-4}$	SN 511	6,5	4,6

¹⁾ These nominal torque settings are suitable for operation with light impacts. If impacts are heavy, an impact factor S of 1.4 must be taken into account.

²⁾ Values valid for St hubs

Speed-length diagram: ZR range

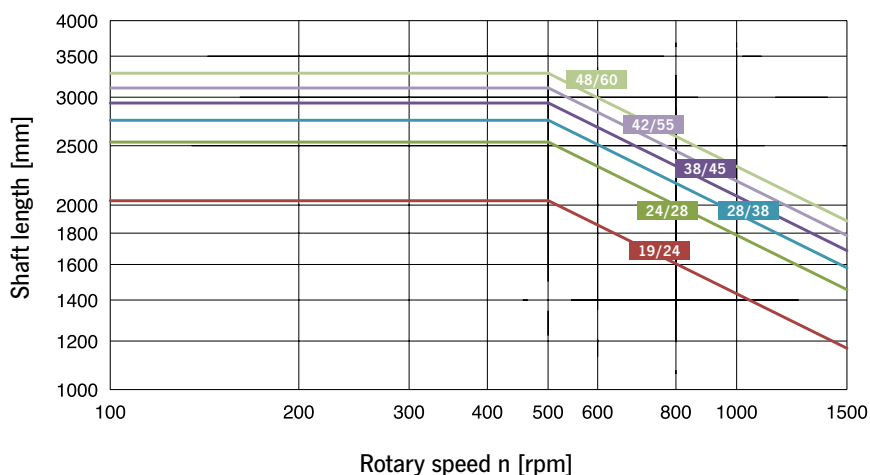

Rotary speed range:

- $n = 1500$ rpm

Operating temperature:

- -40° bis $+90^\circ$ °C
(up to 120° °C for brief periods)

Dimensioning:

The nominal torque (T_N) of the ZR shaft – with **impact factor S** ¹⁾ taken into account – must be at least equal to the system torque (T_{ANL}) to be transferred.

$$T_N \geq T_{ANL} \times S$$

A



C

D

Couplings and connecting shafts

Connecting shafts

Technical drawings: ZR range

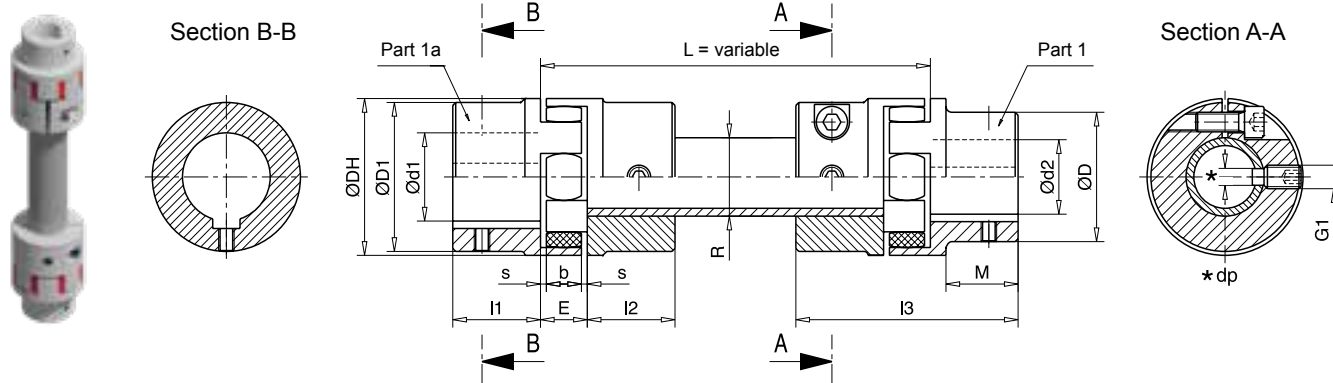

Dimensions: ZR range

Size ZR	Ready-drilled holes ØdH7 ¹⁾				ØDH	ØD	ØD1	ØdH	l1 l2	M	s	b	E	l3	ØR	G1	dp ¹⁾
	Part 1		Part 1a														
	min Ød2	max Ød2	min Ød1	max Ød1													
19/24	6	19	19	24	40	32	41	18	25	20	2	12	16	66	20x3	M6	4
24/28	8	24	24	28	55	40	55	27	30	24	2	14	18	78	30x4	M8	5,5
28/38	10	28	28	38	65	48	65	30	35	28	2,5	15	20	90	35x4	M10	7
38/45	12	38	38	45	80	66	77	38	45	37	3	18	24	114	40x4	M12	8,5
42/55	28	42	42	55	95	75	94	46	50	40	3	20	26	126	45x4	M12	8,5
48/60	28	48	48	60	105	85	102	51	56	45	3,5	21	28	140	50x4	M16	12

¹⁾ Feather key groove conforming to DIN 6885/1



Assembly area Pfaff-silberblau: Special design screw jack SHE 200.1 with 8 m long screw and protection boot. Design for a static load of 400 tons.

A



B



C

D

Couplings and connecting shafts

Connecting shafts

Technical information: G / GX / GZ range

	G range	GX range	GZ range
Rotary speed range	n = 750 rpm	n = 1500 rpm	n = 3000 rpm
Operating temperature	-40 to +90 °C (up to 120 °C for brief periods)	max. 150 °C ²⁾	max. 80 °C



Dimensions: G / GX / GZ range

Size	Nominal torque T_N ^{1), 2)} range			Max. angle displacement		Mass moments of inertia [kgm ²]	Suitable pillow blocks	Weight	
	G [Nm]	GX [Nm]	GZ [Nm]	G+GZ [°]	GX [°]			for 2 hubs [kg]	for 1 m tube length [kg]
1	10	10	10	3	1	0,00021	SN 507	1,0	1,1
2	20	30	20	3	1	0,00052	SN 509	2,2	1,4
4	40	60	40	3	1	0,00076	SN 510	3,4	1,6
8	80	120	80	3	1	0,00185	SN 513	7,3	2,2
16	160	240	160	3	1	0,00297	SN 516	12,4	2,5
25	250	370	250	3	1	0,00538	SN 519	19,1	3,1
30	400	550	400	3	1	0,0116	SN 522	31,1	4,8
50	600	-	600	3	1	0,0116	SN 522	32,1	4,8
90	900	1500	900	3	1	0,0283	SN 528	58,7	7,6

¹⁾ These nominal torque settings are suitable for operation with light impacts. If impacts are heavy, an impact factor S of 1.4 must be taken into account.

²⁾ From +80 °C onwards, the nominal torque is considerably reduced.

Speed-length diagram: G / GX / GZ range

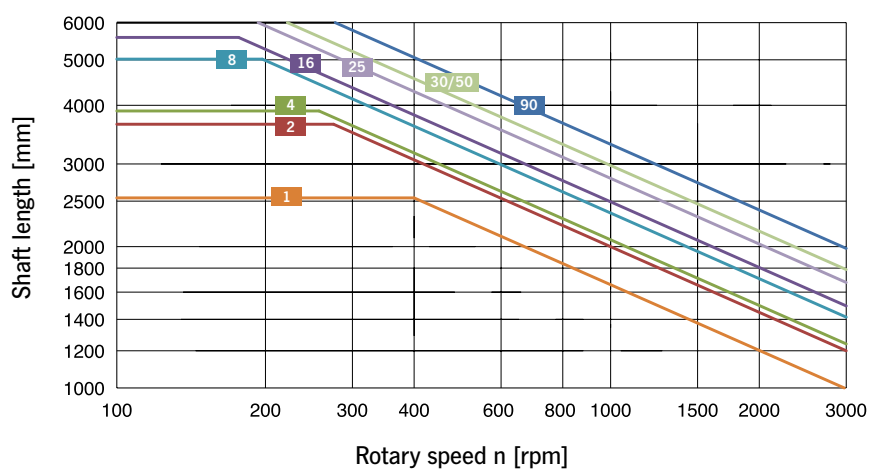

Dimensioning:

The nominal torque (T_N) of the G / GX / GZ shaft – with **impact factor S**¹⁾ taken into account – must be at least equal to the system torque (T_{ANL}) to be transferred.

$$T_N \geq T_{ANL} \times S$$

Couplings and connecting shafts

Connecting shafts

Technical drawings: G / GX / GZ range

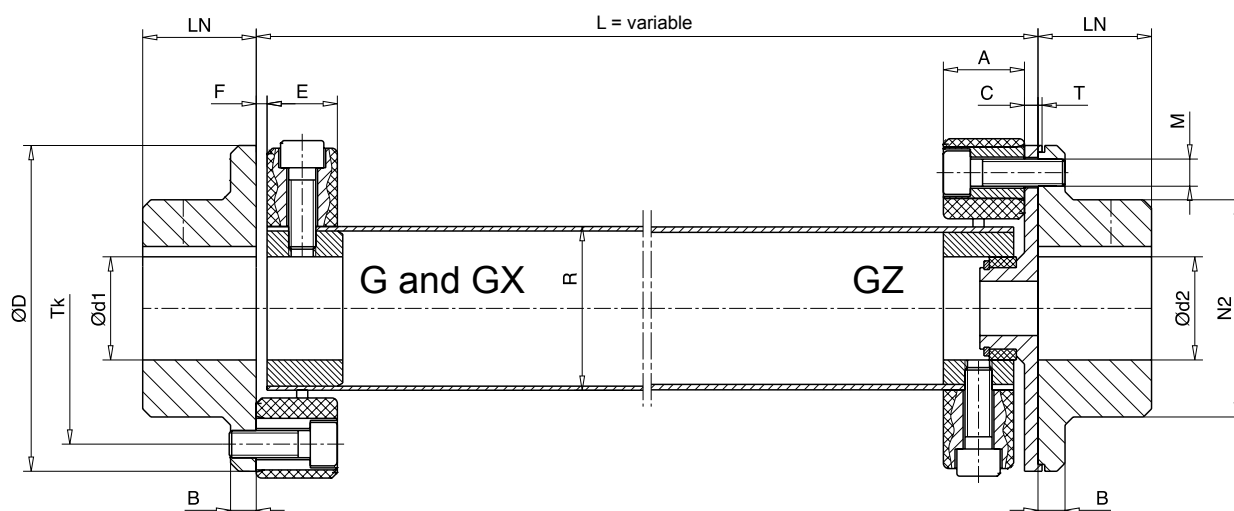

Dimensions: G / GX / GZ range

Size	A	B	C	ØD	Ready-drilled holes ØdH7 ¹⁾ max. Ød1/d2	E	F	L _N	ØN ₂	ØR	T	T _k /M
1	24	7	5	56	25	22	2	24	36	30	1,5	Ø44/2xM6
2	24	8	5	85	38	20	4	28	55	40	1,5	Ø68/2xM8
4	28	8	5	100	45	24	4	30	65	45	1,5	Ø80/3xM8
8	32	10	5	120	55	28	4	42	80	60	1,5	Ø100/3xM10
16	42	12	5	150	70	36	6	50	100	70	1,5	Ø125/3xM12
25	46	14	5	170	85	40	6	55	115	85	1,5	Ø140/3xM14
30	58	16	5	200	100	50	8	66	140	100	1,5	Ø165/3xM16
50	58	16	5	200	100	50	8	66	140	100	1,5	Ø165/3xM16
90	70	19	5	260	110	62	8	80	160	125	2	Ø215/3xM20

¹⁾ Feather key groove conforming to DIN 6885/1

Couplings and connecting shafts

Ordering details

Ordering details couplings

□ □ - □ □ / □ □ - □ □ □ □ - □ □ □ / □ □ □

1 2 3 4 5

No.	Description
1	Range R MKR
2	Size
3	Torque (only for MKR ranges)
4	Hub drill-hole d1
5	Hub drill-hole d2

Ordering details high flexible connecting shafts

□ □ - □ □ / □ □ - □ □ □ □ - □ □ □ / □ □ □

1 2 3 4 5

No.	Description
1	Range ZR G GX GZ
2	Size
3	Length
4	Hub drill-hole d1
5	Hub drill-hole d2

