



## HX-D Scissor elevating platform, mobile with double scissor

**Capacity 350 kg,  
Platform height max. 1300 mm**

For the independant lifting and supplying of light up to medium loads within a warehouse environment.

### Features

- Hydraulic lifting of the load with foot pedal.
- Lowering speed can be finely metered for sensitive lowering of the load.
- Ergonomic handlebar for easy operation.
- Steering roller with brake for safe parking of the hand stacker.
- Robust construction with hard chromium plated piston and pressure relief valve.
- According to DIN EN 1570-1, DIN EN ISO 3691-5.

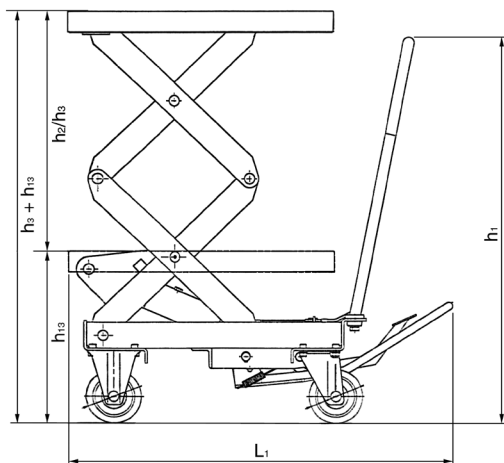
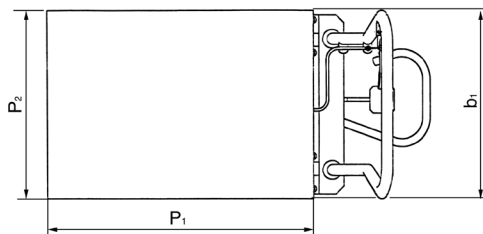

### Technical data HX-D

| Model                                    | HX-D 350 |
|--|----------|
| Art.-No.                                 | 40057361 |
| Capacity, kg                             | 350      |
| Platform height max. $h_3 + h_{13}$ , mm | 1300     |
| Platform height min. $h_{13}$ , mm       | 370      |
| Stroke $h_3$ , mm                        | 930      |
| Lifting height per pump stroke, mm       | 21       |
| Overall height $h_1$ , mm                | 965      |
| Overall length $L_1$ , mm                | 1140     |
| Overall width $b_1$ , mm                 | 500      |
| Platform length $P_1$ , mm               | 910      |
| Platform width $P_2$ , mm                | 500      |
| Tyre type <sup>1</sup>                   | PUR/PUR  |
| Load rollers, mm                         | 128 x 40 |
| Number of wheels/load rollers            | 2/2      |
| Weight, kg                               | 136      |

<sup>1</sup>PUR... Polyurethane