

## HU ES 10 B Scissor pallet truck with electric-hydraulic lift

Capacity 1000 kg,  
Fork height max. 800 mm

The HU ES 10 B increases the usefulness of the HU HS 10 B by saving operating time for demanding applications with frequent lifting and lowering operations.

### Features

- Ergonomic control button for the hydraulic unit fitted in the handle.
- In case of a battery failure the manual use of lifting and lowering is still guaranteed.
- Quick electric-hydraulic lifting of the load, pressure relief valve protects against overloading.
- Low noise and smooth running due to polyurethane steering and load rollers as standard.
- Additional tilting protection for the load rollers.

### Scope of delivery

- Battery and integrated battery charger

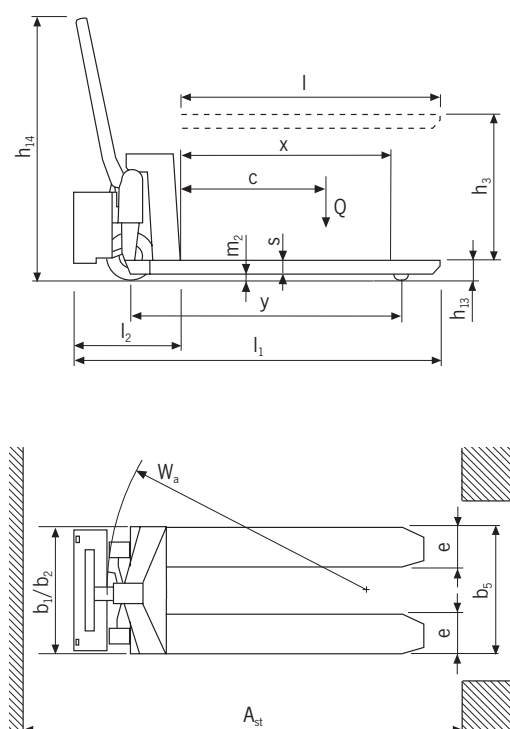

### Technical data HU ES 10 B

Model	HU ES 10 B
Art.-No.	N26900020
Capacity Q, kg	1000
Load center c, mm	600
Weight, kg	152
Tyre type <sup>1</sup>	PUR/PUR
Steering rollers, mm	180 x 50
Load rollers, mm	75 x 50
Number of wheels/load rollers	2/2
Stroke h3, mm	715
Height of control handle max. h14, mm	1254
Fork height lowered h13, mm	85
Overall length l1, mm	1715
Overall width b1/b2, mm	575
Fork height s, mm	45
Fork width e, mm	160
Fork length l, mm	1170
Outside dimension of forks b5, mm	540
Ground clearance, wheelbase centre m2, mm	18
Aisle width pallet Ast, mm	1986
Turning circle radius Wa, mm	1564
Battery charger, V/A	220/6
Battery voltage, capacity K5, V/Ah	12/52

<sup>1</sup>PUR... Polyurethane