



RPY-10 ... (10 t press)  
RPY-23 ... (23 t press)

## RPY and RPES Universal workshop presses

### Capacity 10 - 200 t

For all repair and assembly jobs.

According to European standards, all Yale workshop presses can be used without any additional protection devices as the piston speed is below 10 mm/s.

For special applications additional safety equipment (e.g. protection grid or two-hand-safety-control) can be offered on request.

### Applications

- Pressing and removing of bolts, shafts, bearings.
- Straightening of beams, profiles, axles, shafts.
- Forming, bending, crimping.
- General load tests and tests of weld specimens.
- Stamping, cutting, punching.
- Pre-adjustment of tools.

## Equipment of all presses

### Features

- All workshop presses are ready to use, including hydraulic oil, oil level gauge.
- High pressure-hydraulic hoses.
- Glycerine-damped pressure gauges.
- Fixing holes in base profiles, adjusting device for press table and head, swivelling pump console, conversion chart: Pressure-force etc.

## Description of the hydraulic cylinders

### Features

- Cylinders made from chromium-molybdenum steel, heat-treated and with metric mounting threads in the piston.
- Double bronze bearing of the hard chromium-plated piston.
- Piston return through spring or hydraulically.
- Mounting thread in the piston.
- Available piston strokes from 150 up to 500 mm.

## Description of the press-frames

### Features

- Robust, torsion-resistant construction.
- Solid, precision-welded press-frames.
- Open construction, easily accessible from all sides.
- 50 and 100 tons workshop presses with adjustable press table and press head (frames for adjustments are part of the delivery package).
- 200 t press with adjustable table and fix welded press head.
- Four locking bolts ensure a precisely aligned press head and press table and increase the stability of the frame (50 and 100 t).
- 50, 100 and 200 t presses with pivoting pump table with peripheral passage for straightening of exceptionally long parts.
- Modular system: Large variety of combinations of hydraulic cylinders and pumps possible.
- Drive either by hand or electric hydraulic pumps.



RPY-50 ... (50t press)  
RPY-100 ... (100t press)

## INFO

The press head of the 200 t model is fix welded to the press-frame.

Workshop presses are delivered ready to use.

## Description of the hand pumps

### Features

- All hand pumps with two-stage displacement.
- Glycerine-damped pressure gauge, Ø 63 mm, class 1.6 %.
- Hydraulic hose, L = 2.0 m with male coupler half.

## Description of the hydraulic power packs

### Features

- Longlife radial piston pumps, from 50 t with two-stage displacement.
- Pressure pre-set valve on request (standard equipment for the solenoid valves).
- Glycerine-damped pressure gauge, Ø 100 mm, class 1.0 %.
- Control by manual directional valve (with motor start-stop remote control) or solenoid valve with pendant remote control box.



RPES 10 ... (10t press)  
RPES 30 ... (30t press)

## Technical data RPY and RPES

Model	Art.-No.	Frame design	Capacity t	Cylinder model	Cylinder stroke mm	Piston return	Type of pump	Valve control	Pump model
RPY-1015 M-2	N13700896	bench press	10	YS-10/150	150	spring	manual	manual	HPS-2/0,7 A
RPY-1025 EM-PYE 07	N13700021	bench press	10	YS-10/250	250	spring	electric	manual	PYE-07/3/10/3M-RPY
RPY-2316 M-2	N13700898	bench press	23	YS-23/160	160	spring	manual	manual	HPS-2/0,7 A
RPY-2325 M-2	N13700900	bench press	23	YS-23/250	250	spring	manual	manual	HPS-2/2 A
RPY-2325 EM-PYE 07	N13700017	bench press	23	YS-23/250	250	spring	electric	manual	PYE-07/3/10/3M-RPY
RPES-1015 M-2	N13700004	floor press	10	YS-10/150	150	spring	manual	manual	HPS-2/0,7 A
RPES-1025 EM-PYE 07	N13700022	floor press	10	YS-10/250	250	spring	electric	manual	PYE-07/3/10/3M-RPY
RPES-2316 M-2	N13700006	floor press	23	YS-23/160	160	spring	manual	manual	HPS-2/0,7 A
RPES-2325 M-2	N13700900	floor press	23	YS-23/250	250	spring	manual	manual	HPS-2/2 A
RPES-2325 EM-PYE 07	N13700020	floor press	23	YS-23/250	250	spring	electric	manual	PYE-07/3/10/3M-RPY
RPY-5015 EM	N13701005	floor press	50	YH-50/150	150	hydraulic	electric	manual	PY-04/2/5/4M
RPY-5035 EM	N13700912	floor press	50	YH-50/350	350	hydraulic	electric	manual	PY-04/2/5/4M
RPY-5035 EE	N13700913	floor press	50	YH-50/350	350	hydraulic	electric	solenoid	PYS-07/3/10/4 E
RPY-5050 EE	N13701006	floor press	50	YH-50/500	500	hydraulic	electric	solenoid	PYS-07/3/10/4 E
RPY-10035 EM	N13700914	floor press	100	YH-100/350	350	hydraulic	electric	manual	PY-07/3/10/4 M-RPY
RPY-10035 EE	N13700915	floor press	100	YH-100/350	350	hydraulic	electric	solenoid	PY-07/3/10/4 E
RPY-10050 EM	N13700916	floor press	100	YH-100/500	500	hydraulic	electric	manual	PY-07/3/10/4 M-RPY
RPY-10050 EE	N13701008	floor press	100	YH-100/500	500	hydraulic	electric	solenoid	PY-07/3/10/4 E
RPY-20035 EM	N13700917	floor press	200	YH-200/350	350	hydraulic	electric	manual	PY-11/3/20/4 M-RPY
RPY-20035 EE	N13700918	floor press	200	YH-200/350	350	hydraulic	electric	solenoid	PY-11/3/20/4 E
RPY-20050 EM	N13700919	floor press	200	YH-200/500	500	hydraulic	electric	manual	PY-11/3/20/4 M-RPY
RPY-20050 EE	N13701017	floor press	200	YH-200/500	500	hydraulic	electric	solenoid	PY-11/3/20/4 E

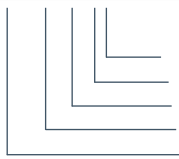

### Code explanation

Valve control : M = manual valve, E = solenoid valve with pendant remote control  
 Pump : M = hand pump, E = electric pump  
 Piston stroke : 15 = 150 mm, 16 = 160 mm, 25 = 250 mm, 35 = 350 mm, 50 = 500 mm  
 Capacity max. : 10 = 10t, 23 = 23t, 50 = 50t, 100 = 100t, 200 = 200t  
 Model

## Dimensions RPY and RPES (frame only)

Model	RPY-10	RPY-23	RPES-10	RPES-23	RPY-50	RPY-100	RPY-200
A min., mm	-	-	50	50	280	270	320
A max., mm	440	440	930	930	1120	830	1000
B, mm	380	380	700	700	820	1000	1000
C, mm	510	510	650	650	1020	1300	1400
D, mm	-	-	500	500	1200	1480	1580
E, mm	180	180	-	-	920	860	1040
F, mm	-	-	150	150	140	140	170
G, mm	-	-	240	240	255	335	450
H, mm	840	840	1695	1695	2000	2000	2430
I, mm	300	300	245	245	315	395	550
K, mm	-	-	-	-	1000	1000	1000
L, mm	-	-	-	-	383	333	400
Weight approx., kg	77	77	94	94	450	950	2380

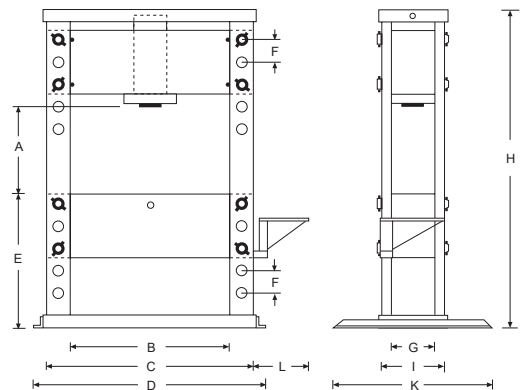

RPY-50, 100 and 200

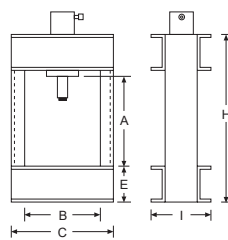

RPY-10 up to 23

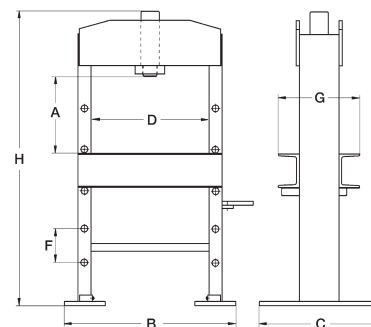

RPES-10 up to 30