

Silverline Stira S Hand chain hoist

Capacity 500 - 5000 kg

The hand chain run is just as smooth as on the models Yalelift 360 and VSIII, but the Silverline Stira S series is a low-priced alternative to the high-quality units.

Features

- Strong bolts between side plates and housing cover ensure increased stability.
- Chain guide rollers eliminate fouling and jamming of chain.
- The design prevents the hand chain from jamming and jumping off.
- Bearings for side plates permit a long service life.
- Zinc-plated load chain as standard.
- Forged suspension and load hooks are made from high tensile steel and fitted with safety latches.



INFO

Yale hoists and trolleys are not designed for passenger elevation applications and must not be used for this purpose.

Technical data Silverline Stira S

Model	Art.-No.	Capacity kg	Number of chain falls	Chain dimensions d x p in mm/ design	Lift per 1 m hand chain overhaul mm	Handle pull at WLL daN	Weight at standard lift (3 m) kg
Stira S 500	N04500041	500	1	6 x 18 - T	29	23	12.0
Stira S 1000	N04500042	1000	1	6 x 18 - T	27	31	14.0
Stira S 1500	N04500043	1500	1	8 x 24 - T	20	32	19.0
Stira S 2000	N04500044	2000	1	8 x 24 - T	15	36	21.0
Stira S 3000	N04500045	3000	2	8 x 24 - T	5	34	27.0
Stira S 5000	N04500046	5000	2	10 x 30 - T	3	41	43.0

Dimensions Silverline Stira S

Model	Stira S 500	Stira S 1000	Stira S 1500	Stira S 2000	Stira S 3000	Stira S 5000
A min.	270	317	399	414	465	636
B	18	23	28	28	35	46
C	30	34	38	41	48	52
D	13	16	20	23	27	35
E	127	158	174	187	199	253
F	131	140	161	161	161	186
G	74	77	82	84	82	93
H	57	63	79	77	79	91
K	220	250	280	300	310	400

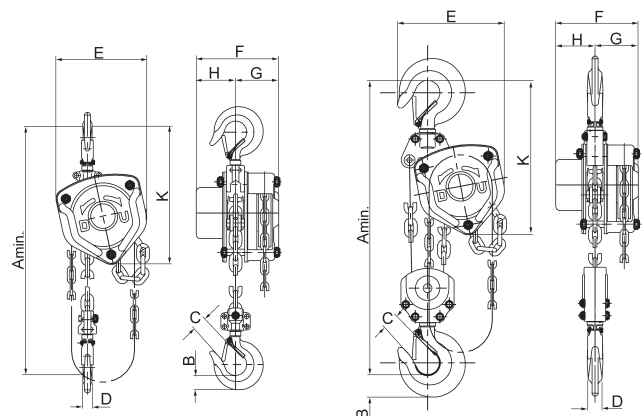

Silverline Stira S
500 - 2000 kg, single fall

Silverline Stira S
3000 - 5000 kg, double fall