

KHB Truck body lifting jack

Capacity 5000 and 8000 kg

Truck body lifting jacks are used for supporting vehicle bridges, swap bodies and trailers; they are also used in vehicle construction and freight forwarding applications.

Features

- High-quality, torsionally stiff steel design with large base plate for a high level of stability.
- Hardened gearing parts and precisely machined teeth for improved handling and low wear.
- The load can either be supported on the head or on the adjustable claw.



KHB 5
capacity 5000 kg



KHB 8
capacity 8000 kg

Technical data KHB Siku

Model	Art.-No. Siku	Capacity kg	Height mm	Lift ¹ mm	Hand effort at WLL daN	Dim. B mm	Dim. C mm	Dim. D mm	Dim. E mm	Dim. F mm	Dim. O/P mm	Weight kg
KHB 5000/500	30077011	5000	1100	500	18	540	500	80	140	250	70/70	80
KHB 8000/500	30080012	8000	1100	500	26	540	500	100	170	300	150/180	111

¹Height of lift = Height + Lift

Step height of adjustable lifting claw

Model	KHB 5000	KHB 8000
1. step, mm	175	290
2. step, mm	230	396
3. step, mm	285	502
4. step, mm	340	608
5. step, mm	395	714
6. step, mm	450	820
7. step, mm	505	926
8. step, mm	560	1032
9. step, mm	615	-
10. step, mm	670	-
11. step, mm	725	-
12. step, mm	780	-
13. step, mm	835	-
14. step, mm	890	-

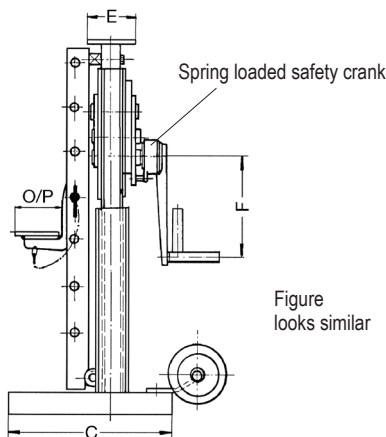

Figure looks similar

