

HU W-20 G GREENLINE Hand pallet truck with weighing system

Capacity 2000 kg

For transportation and weighing of palletised goods and box pallets.

Features

- Ergonomic safety control handle for one-hand operation of lifting, driving and lowering.
- Large keypad for easy and convenient operation.
- Measuring range from 0 up to 2000 kg in 0.2 kg steps.
- Easy to read LCD display.
- Accuracy $\pm 0.1\%$ of the end value.
- Protection IP55

Scope of delivery

- Integrated battery and charger

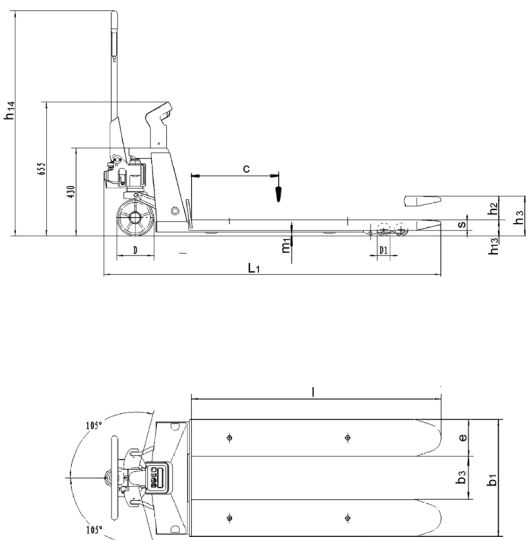

Technical data HU W-20 G

Model	HU W-20 G
Art.-No.	N21220640
Capacity, kg	2000
Load center c, mm	600
Weight, kg	115
Tyre type ¹	PUR/PUR
Steering rollers D, mm	200 x 50
Load rollers D1, mm	80 x 57
Number of wheels/load rollers	2/4
Stroke h2, mm	115
Lifting height h3, mm	200
Height of control handle h14, mm	1235
Fork height lowered h13, mm	85
Overall length L1, mm	1570
Fork height s, mm	50
Fork width e, mm	180
Fork length l, mm	1150
Outside dimension of forks b1, mm	555
Ground clearance m1, mm	35
Turning circle radius, mm	1330
Ambient temperature	-5°C up to +40°C

¹PUR ... Polyurethane