

H&S
TOOL
A **CLIMAX** COMPANY

Split Frame Clamshells and Accessories

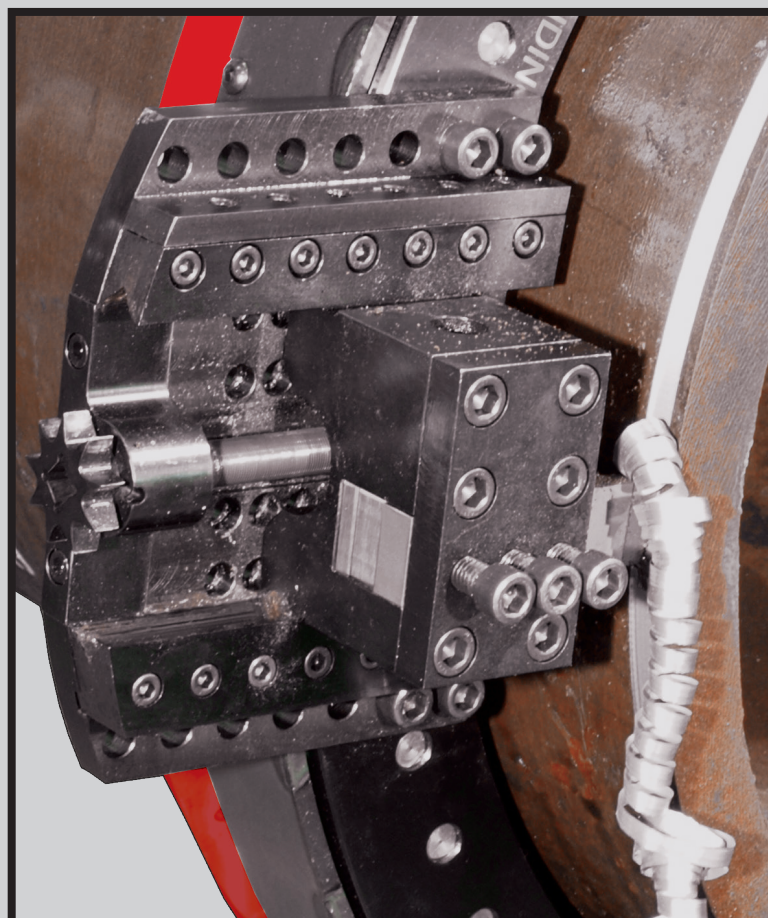
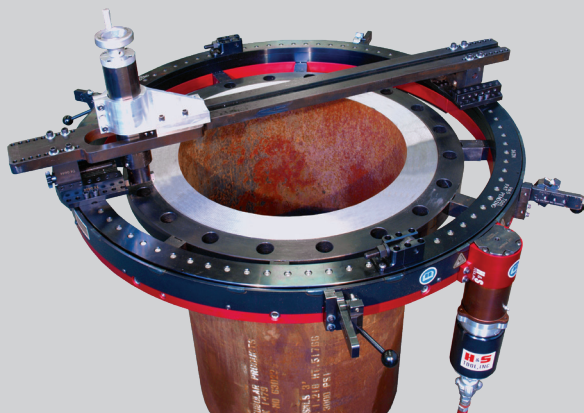
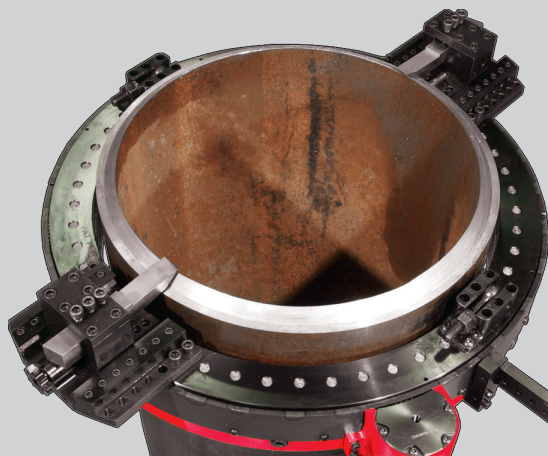

Sever and Machine Pipes From .625" to 86" (15.9 mm to 2184.4 mm)

- **Rigid And Easy To Handle - Aluminum Body Gives Highest Strength-To-Weight Ratio And Our Exclusive Ring-Mounted Bearing Design Has A Patent Pending**
- **Lower Overall Investment - Complete Parts Interchangeability Between Models Within Series**
- **Greater Reliability - Our Unique Motor Drive Is Protected by U.S. Patent #7,690,283 B1**
- **Easy Setup And Accurate Cuts - Improved Tool Slide Design**
- **Low-Clearance Design**
- **Patent Pending Safety Tripper Mechanism**
- **Adjustable Locator Pads Have 3/4" (19 mm) Clamping Adjustment Per Pad Which Minimizes The Number Of Locator Extensions Required For Full Model Range Coverage**
- **Easy Alignment And Squaring**
- **Rental And Purchase**

Built for Field Production

There are three series of H&S split frame pipe machining tools to meet the demands of your specific project.

Our MFC small diameter series has big performance and reliability for materials from .625" to 2.625" O.D. (15.9 to 66.7 mm).

The versatile AFC series cuts and forms pipes from 1" O.D. to 48" O.D. (25.4 to 1219.2 mm).

Our heavier duty BFC series features a thicker body to withstand the high torque required for heavy wall pipes in large diameters. They are available for pipes from 22" to 86" O.D. (558.8 to 2184.4 mm).

We constantly seek to minimize your overall investment by utilizing a high percentage of parts interchangeability and by reducing the number of extension pads necessary to achieve the full working range.

From every point of comparison, H&S Tool field machining pipe tools are designed for greater productivity, reliability and economy.



Engineered for Accuracy

The H&S Tool split-frame machine design is a unique combination of accuracy, strength and ease of handling. Our engineers have gathered information from field-operators around the world to determine the areas needing improvement over traditional designs.

Our engineering minimizes weight while maximizing strength and rigidity with a quality aluminum body. The patent protected pocket-style motor mount eliminates motor twisting and ring gear damage. The mount also allows you to switch between the pneumatic, electric and hydraulic motors without the need for conversion pieces. Conventional motors are also used on the front drive adapters eliminating the need for secondary motors.

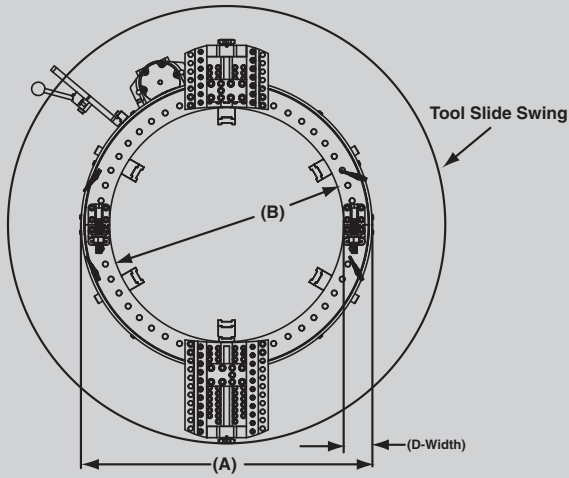

MFC-2
C = 2.3" 58.4 mm
D = 1.6" 40.6 mm
E = 3.3" 83.8 mm

AFC-4 to AFC 48
C = 3.4" 86.4 mm
D = 2.5" 63.5 mm
E = 5.1" 129.5 mm

F =
Pneumatic
MFC-2 = 2.670" 67.8 mm
AFC-4, -6, -8 & -10 = 9.1" 231.1 mm
AFC-12 & Larger = 11.0" 279.4 mm

Electric = 15.1" 383.5 mm
Hydraulic = 6.9" 175.3 mm

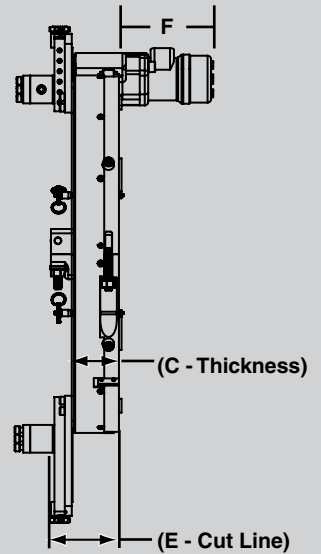

MFC Series*					
Model	Working Range	A	B	1" Slide Swing	Pads
MFC-2	.625" - 2.625"	5.773"	2.625"	5.634"	4
	mm 15.9 - 66.7	146.6	66.7	143.1	

*The MFC's design is unique and has substantially different parts and accessories than the AFC and BFC. The drawings above do not reflect the actual appearance of the MFC and are intended solely for transmitting dimensional data.

AFC Series									
Model	Nom. Pipe Size	A	B	1" Slide Swing	2" Slide Swing	3" Slide Swing	4" Slide Swing	7" Slide Swing	Locator Pads
AFC-4	1" - 4"	10.026"	5.000"	10.649"	12.869"	14.921"	16.921"		4
	mm 33.4 - 114.3	254.7	127.0	270.5	326.9	379.0	429.8		
AFC-6	2" - 6"	12.150"	7.125"	12.801"	15.021"	17.073"	19.073"		4
	mm 60.3 - 168.3	308.6	181.0	325.1	381.5	433.7	484.4		
AFC-8	3" - 8"	14.149"	9.125"	15.149"	17.369"	19.423"	21.421"	27.370"	4
	mm 88.9 - 219.1	359.4	231.8	384.8	441.2	493.3	544.1	695.2	
AFC-10	4" - 10"	16.315"	11.250"	17.468"	19.688"	21.740"	23.740"	29.688"	4
	mm 114.3 - 273.1	414.40	285.75	443.7	500.1	552.2	603.0	754.1	
AFC-12	6" - 12"	18.400"	13.250"	19.014"	21.234"	23.286"	25.286"	31.234"	4
	mm 152.4 - 323.9	467.4	336.6	483.0	539.3	591.5	642.3	793.3	
AFC-14	6" - 14"	19.650"	14.500"	20.228"	22.448"	24.500"	26.500"	32.449"	4
	mm 168.3 - 355.6	499.11	368.3	513.8	570.18	622.3	673.1	824.2	
AFC-16	8" - 16"	21.650"	16.500"	22.117"	24.337"	26.389"	28.389"	34.337"	6
	mm 219.1 - 406.4	549.9	419.1	561.8	618.2	670.3	721.1	872.2	
AFC-18	10" - 18"	23.900"	18.750"	24.540"	26.76"	28.812"	30.812"	36.761"	6
	mm 273.1 - 457.2	607.1	476.2	623.3	679.7	731.8	782.6	933.7	
AFC-20	12" - 20"	25.776"	20.750"	26.520"	28.740"	30.792"	32.792"	38.740"	6
	mm 323.9 - 508.0	654.7	527.1	673.6	730.0	782.1	832.9	984.0	
AFC-24	16" - 24"	29.776"	24.750"	30.439"	32.659"	34.711"	36.711"	42.659"	10
	mm 406.4 - 609.6	756.3	628.7	773.2	829.5	881.7	932.5	1083.5	
AFC-26	18" - 26"	31.900"	26.750"	32.503"	34.723"	36.775"	38.775"	44.723"	10
	mm 457.2 - 660.4	810.3	679.5	825.6	882.0	934.1	984.9	1124.5	
AFC-28	20" - 28"	33.900"	28.750"	34.558"	36.778"	38.830"	40.830"	46.778"	10
	mm 508.0 - 711.2	861.1	730.3	877.8	934.0	986.3	1037.1	1188.2	
AFC-30	22" - 30"	36.150"	31.000"	36.861"	39.081"	41.133"	43.133"	49.082"	10
	mm 558.8 - 762.0	918.2	781.1	931.7	988.0	1040.3	1091.6	1242.7	
AFC-32	24" - 32"	38.150"	33.000"	38.902"	41.122"	43.166"	45.174"	51.123"	10
	mm 609.6 - 812.8	969.0	838.2	988.1	1044.5	1096.4	1147.4	1298.5	
AFC-36	28" - 36"	42.150"	37.000"	42.978"	45.198"	47.250"	49.250"	55.199"	10
	mm 711.2 - 914.4	1070.6	939.8	1091.6	1148.0	1200.2	1251.0	1402.1	
AFC-42	34" - 42"	48.150"	43.000"	49.049"	51.269"	53.321"	55.321"	61.270"	10
	mm 863.6 - 1066.8	1223.0	1092.2	1245.8	1302.2	1354.4	1405.2	1556.3	
AFC-48	40" - 48"	54.400"	49.250"	54.900"	57.120"	59.172"	61.172"	67.120"	12
	mm 1016.0 - 1219.2	1381.8	1251.0	1394.5	1450.8	1503.0	1553.8	1704.8	

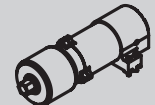

Pneumatic

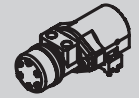

Hydraulic

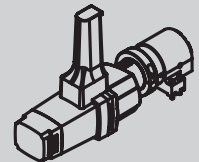

Electric

MFC Locator Extensions Coverage

STANDARD RANGE 1/2"

MFC-2	2.625" - 1.450"	1.550" - 0.625"
mm	66.7 - 36.8	39.3 - 15.9

AFC Locator Extensions Coverage

STANDARD RANGE 1/2" 1" 1.5" 2" 2.5" 3" 3.5" 4"

AFC-4	5.000" - 3.500" mm 127 - 88.9	4.000" - 2.500" mm 101.6 - 63.5	3.000" - 1.500" mm 76.2 - 38.1	2.000" - 0.500" mm 50.8 - 12.7						
AFC-6	7.125" - 5.625" mm 181.0 - 142.9	6.125" - 4.625" mm 155.6 - 117.5	5.125" - 3.625" mm 130.2 - 92.1	4.125" - 2.625" mm 104.8 - 66.7	3.125" - 1.625" mm 79.4 - 41.3					
AFC-8	9.125" - 7.625" mm 231.8 - 193.7	8.125" - 6.625" mm 206.4 - 168.3	7.125" - 5.625" mm 181.0 - 142.9	6.125" - 4.625" mm 155.6 - 117.5	5.125" - 3.625" mm 130.2 - 92.1	4.125" - 2.625" mm 104.8 - 66.7				
AFC-10	11.250" - 9.750" mm 285.8 - 247.7	10.250" - 8.750" mm 260.4 - 222.3	9.250" - 7.750" mm 235.0 - 196.9	8.250" - 6.750" mm 209.6 - 171.5	7.250" - 5.750" mm 184.2 - 146.1	6.250" - 4.750" mm 158.8 - 120.7	5.250" - 3.750" mm 133.4 - 95.3			
AFC-12	13.250" - 11.750" mm 336.6 - 298.5	12.250" - 10.750" mm 311.2 - 273.1	11.250" - 9.750" mm 285.8 - 247.7	10.250" - 8.750" mm 260.4 - 222.3	9.250" - 7.750" mm 235.0 - 196.9	8.250" - 6.750" mm 209.6 - 171.5	7.250" - 5.750" mm 184.2 - 146.1	6.250" - 4.750" mm 158.8 - 120.7		
AFC-14	14.500" - 13.000" mm 368.3 - 330.2	13.500" - 12.000" mm 342.9 - 304.8	12.500" - 11.000" mm 317.5 - 279.4	11.500" - 10.000" mm 292.1 - 254.0	10.500" - 9.000" mm 266.7 - 228.6	9.500" - 8.000" mm 241.3 - 203.2	8.500" - 7.000" mm 215.9 - 177.8	7.500" - 6.000" mm 190.5 - 152.4	6.500" - 5.000" mm 165.1 - 127.0	
AFC-16	16.500" - 15.000" mm 419.1 - 381.0	15.500" - 14.000" mm 393.7 - 355.6	14.500" - 13.000" mm 368.3 - 330.2	13.500" - 12.000" mm 342.9 - 304.8	12.500" - 11.000" mm 317.5 - 279.4	11.500" - 10.000" mm 292.1 - 254.0	10.500" - 9.000" mm 266.7 - 228.6	9.500" - 8.000" mm 241.3 - 203.2	8.500" - 7.000" mm 215.9 - 177.8	
AFC-18	18.750" - 17.250" mm 476.3 - 438.2	17.750" - 16.250" mm 450.9 - 412.8	16.750" - 15.250" mm 425.5 - 387.4	15.750" - 14.250" mm 400.1 - 362.0	14.750" - 13.250" mm 374.7 - 336.6	13.750" - 12.250" mm 349.3 - 311.2	12.750" - 11.250" mm 323.9 - 285.8	11.750" - 10.250" mm 298.5 - 260.4	10.750" - 9.250" mm 273.1 - 235.0	
AFC-20	20.750" - 19.250" mm 527.1 - 489.9	19.750" - 18.250" mm 501.7 - 463.6	18.750" - 17.250" mm 476.3 - 438.2	17.750" - 16.250" mm 450.9 - 412.8	16.750" - 15.250" mm 425.5 - 387.4	15.750" - 14.250" mm 400.1 - 362.1	14.750" - 13.250" mm 374.7 - 336.6	13.750" - 12.250" mm 349.3 - 311.2	12.750" - 11.250" mm 323.9 - 285.8	
AFC-24	24.750" - 23.250" mm 628.7 - 590.6	23.750" - 22.250" mm 603.3 - 565.2	22.750" - 21.250" mm 577.9 - 539.8	21.750" - 20.250" mm 552.5 - 514.4	20.750" - 19.250" mm 527.1 - 489.0	19.750" - 18.250" mm 501.7 - 463.6	18.750" - 17.250" mm 476.3 - 438.2	17.750" - 16.250" mm 450.9 - 362.0	16.750" - 15.250" mm 425.5 - 387.4	
AFC-26	26.750" - 25.250" mm 679.5 - 641.4	25.750" - 24.250" mm 654.0 - 616.0	24.750" - 23.250" mm 628.65 - 590.6	23.750" - 22.250" mm 603.25 - 565.2	22.750" - 21.250" mm 577.9 - 539.8	21.750" - 20.250" mm 552.5 - 514.4	20.750" - 19.250" mm 527.1 - 489.0	19.750" - 18.250" mm 501.7 - 463.6	18.750" - 17.250" mm 476.3 - 438.2	
AFC-28	28.750" - 27.250" mm 730.3 - 692.2	27.750" - 26.250" mm 704.9 - 666.8	26.750" - 25.250" mm 679.5 - 641.4	25.750" - 24.250" mm 654.0 - 616.0	24.750" - 23.250" mm 628.7 - 590.6	23.750" - 22.250" mm 603.3 - 565.2	22.750" - 21.250" mm 577.9 - 539.8	21.750" - 20.250" mm 552.5 - 514.4	20.750" - 19.250" mm 527.9 - 489.0	
AFC-30	31.000" - 29.500" mm 787.4 - 749.3	30.000" - 28.500" mm 762.0 - 723.9	29.000" - 27.500" mm 736.6 - 698.5	28.000" - 26.500" mm 711.20 - 673.1	27.000" - 25.500" mm 685.8 - 647.7	26.000" - 24.500" mm 660.4 - 622.3	25.000" - 23.500" mm 635.00 - 596.9	24.000" - 22.500" mm 609.6 - 571.5	23.000" - 21.500" mm 584.2 - 546.1	
AFC-32	33.000" - 31.500" mm 838.2 - 800.1	32.000" - 30.500" mm 812.8 - 774.7	31.000" - 29.500" mm 787.4 - 749.3	30.000" - 28.500" mm 762.0 - 723.9	29.000" - 27.500" mm 736.6 - 698.5	28.000" - 26.500" mm 711.2 - 673.1	27.000" - 25.500" mm 685.8 - 647.7	26.000" - 24.500" mm 660.4 - 622.3	25.000" - 23.500" mm 635.0 - 596.9	
AFC-36	37.000" - 35.500" mm 939.8 - 901.7	36.000" - 34.500" mm 914.4 - 876.3	35.000" - 33.500" mm 889.0 - 850.9	34.000" - 32.500" mm 863.6 - 825.5	33.000" - 31.500" mm 838.2 - 800.1	32.000" - 30.500" mm 812.8 - 774.7	31.000" - 29.500" mm 787.4 - 749.3	30.000" - 28.500" mm 762.0 - 723.9	29.000" - 27.500" mm 736.6 - 698.5	
AFC-42	43.000" - 41.500" mm 1092.2 - 1054.1	42.000" - 40.500" mm 1066.8 - 1028.7	41.000" - 39.500" mm 1041.4 - 1003.3	40.000" - 38.500" mm 1016.0 - 977.9	39.000" - 37.500" mm 990.6 - 952.5	38.000" - 36.500" mm 965.2 - 927.1	37.000" - 35.500" mm 939.8 - 901.7	36.000" - 34.500" mm 914.4 - 876.3	35.000" - 33.500" mm 889.0 - 850.9	
AFC-48	49.250" - 47.750" mm 1251.0 - 1212.9	48.250" - 46.750" mm 1225.6 - 1187.5	47.250" - 45.750" mm 1200.2 - 1162.1	46.250" - 44.750" mm 1174.8 - 1136.7	45.250" - 43.750" mm 1149.4 - 1111.3	44.250" - 42.750" mm 1124.0 - 1085.9	43.250" - 41.750" mm 1098.6 - 1060.5	42.250" - 40.750" mm 1073.2 - 1035.1	41.250" - 39.750" mm 1047.8 - 1009.7	



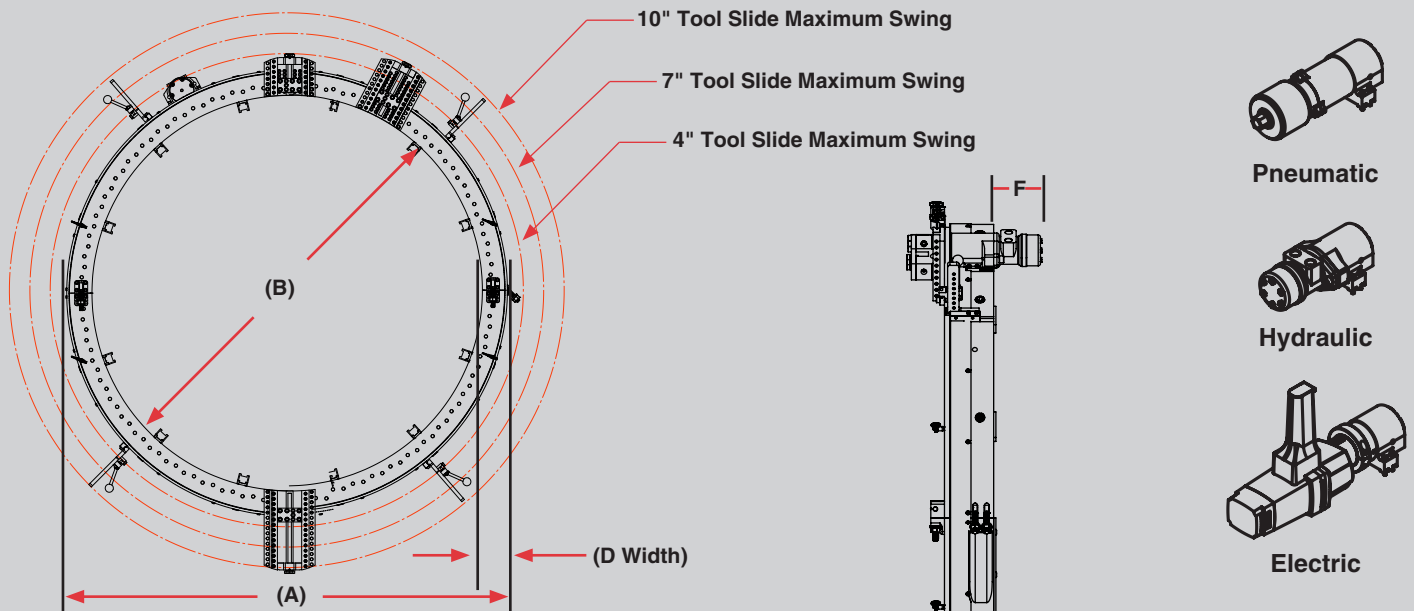

BFC Series Clamshells

Model	Nom. Pipe Size	A	B	4\"/>			
BFC-36	22" - 36"	44.170"	37.000"	49.118"	55.068"	61.065"	10
	mm 558.8 - 914.4	1121.9	939.8	1247.6	1398.7	1551.1	
BFC-42	28" - 42"	50.170"	43.000"	55.196"	61.146"	67.144"	10
	mm 711.2 - 1066.9	1274.3	1092.2	1402.0	1553.1	1705.5	
BFC-48	34" - 48"	56.420"	49.250"	61.507"	67.457"	73.455"	12
	mm 863.6 - 1219.2	1433.1	1251.0	1562.3	1713.4	1865.8	
BFC-56	42" - 56"	64.420"	57.250"	69.229"	75.179"	81.177"	12
	mm 1066.8 - 1422.4	1636.3	1454.2	1758.4	1909.5	2061.9	
BFC-66	52" - 66"	74.754"	67.500"	79.671"	85.621"	91.619"	12
	mm 1320.8 - 1676.4	1898.8	1714.5	2023.6	2174.8	2327.1	
BFC-72	58" - 72"	80.904"	73.500"	85.672"	91.608"	97.626"	12
	mm 1473.2 - 1828.8	2054.9	1866.9	2176.0	2326.8	2479.7	
BFC-86	72" - 86"	94.904"	87.500"	99.671"	105.621"	111.618"	12
	mm 1828.8 - 2184.4	2410.5	2222.5	2531.6	2682.7	2835.1	

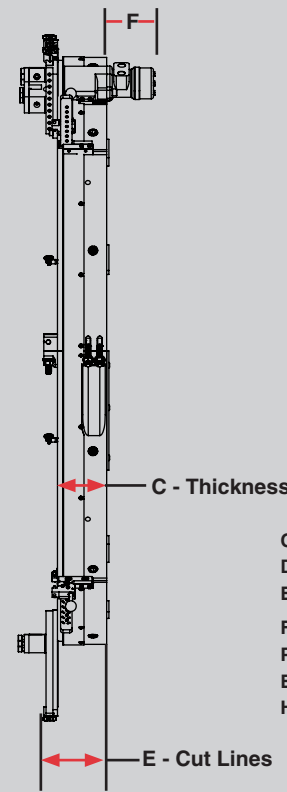

- C = 5.4" 137.2 mm
- D = 3.6" 91.4 mm
- E = 7.2" 182.9 mm
- F =
- Pneumatic = 11" 279.4 mm
- Electric = 15.1" 383.5 mm
- Hydraulic = 6.9" 175.3 mm

BFC Locator Extensions Coverage*

	STANDARD RANGE	½"	1"	1.5"	2"	2.5"	3"	3.5"	4"
BFC-36	37.000" - 35.500"	36.000" - 34.500"	35.000" - 33.500"	34.000" - 32.500"	33.000" - 31.500"	32.000" - 30.500"	31.000" - 29.500"	30.000" - 28.500"	29.000" - 27.500"
	mm 939.8 - 901.7	914.4 - 876.3	889.0 - 850.9	863.6 - 825.5	838.2 - 800.1	812.8 - 774.7	787.4 - 749.3	762.0 - 723.9	736.6 - 698.5
BFC-42	43.000" - 41.500"	42.000" - 40.500"	41.000" - 39.500"	40.000" - 38.500"	39.000" - 37.500"	38.000" - 36.500"	37.000" - 35.500"	36.000" - 34.500"	35.000" - 33.500"
	mm 1092.2 - 1054.1	1066.8 - 1028.7	1041.4 - 1003.3	1016.0 - 977.9	990.6 - 952.5	965.2 - 927.1	939.8 - 901.7	914.4 - 876.3	889.0 - 850.9
BFC-48	49.250" - 47.750"	48.250" - 46.750"	47.250" - 45.750"	46.250" - 44.750"	45.250" - 43.750"	44.250" - 42.750"	43.250" - 41.750"	42.250" - 40.750"	41.250" - 39.750"
	mm 1251.0 - 1212.9	1225.6 - 1187.5	1200.2 - 1162.1	1174.8 - 1136.7	1149.4 - 1111.3	1124.0 - 1085.9	1098.6 - 1060.5	1073.2 - 1035.1	1047.8 - 1009.7
BFC-56	57.250" - 55.750"	56.250" - 54.750"	55.250" - 53.750"	54.250" - 52.750"	53.250" - 51.750"	52.250" - 50.750"	51.250" - 49.750"	50.250" - 48.750"	49.250" - 47.750"
	mm 1454.2 - 1416.1	1428.8 - 1390.7	1403.4 - 1365.3	1378.0 - 1339.9	1352.6 - 1314.5	1327.2 - 1289.1	1301.8 - 1263.7	1276.4 - 1238.3	1251.0 - 1200.2
BFC-66	67.500" - 66.000"	66.500" - 65.000"	65.500" - 64.000"	64.500" - 63.000"	63.500" - 62.000"	62.500" - 61.000"	61.500" - 60.000"	60.500" - 59.000"	59.500" - 58.000"
	mm 1714.5 - 1676.4	1689.1 - 1651.0	1663.7 - 1625.6	1638.3 - 1600.2	1612.9 - 1574.8	1587.5 - 1549.4	1562.1 - 1524.0	1536.7 - 1498.6	1511.3 - 1473.2
BFC-72	73.500" - 72.000"	72.500" - 71.000"	71.500" - 70.000"	70.500" - 69.000"	69.500" - 68.000"	68.500" - 67.000"	67.500" - 66.000"	66.500" - 65.000"	65.500" - 64.000"
	mm 1866.9 - 1828.8	1841.5 - 1803.4	1816.1 - 1778.0	1790.7 - 1752.6	1765.3 - 1727.2	1739.9 - 1701.8	1714.5 - 1676.4	1689.1 - 1651.0	1663.7 - 1625.6
BFC-86	87.500" - 86.000"	86.500" - 85.000"	85.500" - 84.000"	84.500" - 83.000"	83.500" - 82.000"	82.500" - 81.000"	81.500" - 80.000"	80.500" - 79.000"	79.500" - 78.000"
	mm 2222.5 - 2184.4	2197.1 - 2159.0	2171.7 - 2133.6	2146.3 - 2108.2	2120.9 - 2082.8	2095.5 - 2057.4	2070.1 - 2032.0	2044.7 - 2006.6	2019.3 - 1981.2
		4.5"	5"	5.5"	6"	6.5"	7"	8"	
BFC-36		28.000" - 26.500"	27.000" - 25.500"	26.000" - 24.500"	25.000" - 23.500"	24.000" - 22.500"	23.000" - 21.500"	N/A	
		mm 711.2 - 673.1	685.8 - 647.7	660.4 - 622.3	635.0 - 596.9	609.6 - 571.5	584.2 - 546.1		
BFC-42		34.000" - 32.500"	33.000" - 31.500"	32.000" - 30.500"	31.000" - 29.500"	30.000" - 28.500"	29.000" - 27.500"	N/A	
		mm 863.6 - 825.5	838.2 - 800.1	812.8 - 774.7	787.4 - 749.3	762.0 - 723.9	736.6 - 698.5		
BFC-48		40.250" - 38.750"	39.250" - 37.750"	38.250" - 36.750"	37.250" - 35.750"	36.250" - 34.750"	35.250" - 33.750"	N/A	
		mm 1022.4 - 984	997.0 - 958.9	971.6 - 933.5	946.2 - 908.1	920.8 - 882.7	895.4 - 857.3		
BFC-56		48.250" - 46.750"	47.250" - 45.750"	46.250" - 44.750"	45.250" - 43.750"	44.250" - 42.750"	43.250" - 41.750"	41.250" - 39.750"	
		mm 1022.4 - 1187.5	1200.2 - 1162.1	1174.8 - 1136.7	1149.4 - 1111.3	1124.0 - 1085.9	1098.6 - 1060.5	1047.8 - 1009.7	
BFC-66		58.500" - 57.000"	57.500" - 56.000"	56.500" - 55.000"	55.500" - 54.000"	54.500" - 53.000"	53.500" - 52.000"	51.500" - 50.000"	
		mm 1485.9 - 1447.8	1460.5 - 1422.4	1435.1 - 1397.0	1409.7 - 1371.6	1384.3 - 1346.2	1358.9 - 1320.8	1308.1 - 1270.0	
BFC-72		64.500" - 63.000"	63.500" - 62.000"	62.500" - 61.000"	61.500" - 60.000"	60.500" - 59.000"	59.500" - 58.000"	57.500" - 56.000"	
		mm 1638.3 - 1600.2	1612.9 - 1574.8	1587.5 - 1549.4	1562.1 - 1524.0	1536.7 - 1498.6	1511.3 - 1473.2	1460.1 - 1422.4	
BFC-86		78.500" - 77.000"	77.500" - 76.000"	76.500" - 75.000"	75.500" - 74.000"	74.500" - 73.000"	73.500" - 72.000"	71.500" - 70.000"	
		mm 1993.9 - 1955.8	1968.5 - 1930.4	1943.1 - 1905.0	1917.7 - 1879.6	1892.3 - 1854.2	1866.9 - 1828.8	1816.1 - 1778.0	

*All locator extensions over 4" (101.6 mm) are achieved by combining other sizes (i.e. 7" [177.8 mm] can use a 4" and 3" [101.6 and 76.2 mm] or a 4", 2" and 1" [101.6, 50.8 and 25.4 mm]).

Standard Pipe Sizes

Size	O.D.	Schedule											
		5S		10(S)		20 (ST)		30 (XS)		40 (S-ST)		60	
		Wall	I.D.	Wall	I.D.	Wall	I.D.	Wall	I.D.	Wall	I.D.	Wall	I.D.
1"	1.315"	.065"	1.185"	.109"	1.097"					.133"	1.049"		
mm	33.4	1.7	30.1	2.8	27.9					3.4	26.6		
1-1/4"	1.660"	.065"	1.530"	.109"	1.442"					.140"	1.380"		
mm	42.2	1.7	38.9	2.8	36.6					3.6	35.1		
1-1/2"	1.900"	.065"	1.770"	.109"	1.682"					.145"	1.610"		
mm	48.3	1.7	45.0	2.8	42.7					3.7	40.9		
2"	2.375"	.065"	2.245"	.109"	2.157"					.154"	2.067"		
mm	60.3	1.7	57.0	2.8	54.8					3.9	52.5		
2-1/2"	2.875"	.083"	2.709"	.120"	2.635"					.203"	2.469"		
mm	73.0	2.1	68.8	3.0	66.9					5.2	62.7		
3"	3.500"	.083"	3.334"	.120"	3.260"					.216"	3.068"		
mm	88.9	2.1	84.7	3.0	82.8					5.5	77.9		
4"	4.500"	.083"	4.334"	.120"	4.260"					.237"	4.026"		
mm	114.3	2.1	110.1	3.0	108.2					6.0	102.3		
5"	5.563"	.109"	5.345"	.134"	5.295"					.258"	5.047"		
mm	141.3	2.8	135.8	3.4	134.5					6.6	128.2		
6"	6.625"	.109"	6.407"	.134"	6.357"					.280"	6.065"		
mm	168.3	2.8	162.7	3.4	161.5					7.1	154.1		
8"	8.625"	.109	8.407"	.148"	8.329"	.250"	8.125"	.277"	8.071"	.322"	7.981"	.406"	7.813"
mm	219.1	2.8	213.5	3.8	211.6	6.4	206.4	7.0	205.0	8.2	202.7	10.3	198.5
10"	10.750"	.134"	10.482"	.165"	10.420"	.250"	10.250"	.307"	10.136"	.365"	10.020"	.500"	9.750"
mm	273.1	3.4	266.2	4.2	2.6	6.4	260.4	7.8	257.5	9.3	254.5	12.7	501.7
12"	12.750"	.156"	12.438"	.180"	10.420"	.250"	12.250"	.330"	12.090"	.375"	12.000"	.406"	11.938"
mm	323.9	4.0	315.9	4.6	264.7	6.4	311.2	8.4	307.1	9.5	304.8	10.3	303.2
14"	14.000"	.156"	13.688"	.188"	13.624"	.250"	13.500"	.312"	13.376"	.375"	13.250"	.438"	13.124"
mm	355.6	4.0	347.7	4.8	346.0	6.4	342.9	7.9	339.8	9.5	336.6	11.1	333.3
16"	16.000"	.165"	15.670"	.188"	15.624"	.250"	15.500"	.312"	15.376"	.375"	15.250"	.500"	15.000"
mm	406.4	4.2	398.0	4.8	396.8	6.4	393.7	7.9	390.6	9.5	387.4	12.7	381.0
18"	18.000"	.165"	17.670"	.188"	17.624"	.250"	17.500"	.312"	17.376"	.375"	17.250"	.438"	17.124"
mm	457.2	4.2	448.8	4.8	447.6	6.4	444.5	7.9	441.4	9.5	438.2	11.1	434.9
20"	20.000"	.188"	19.624"	.250"	19.500"	.375"	19.250"	.500"	19.000"	.594"	18.812"	.812	18.376
mm	508.0	4.8	498.4	6.4	495.3	9.5	489.0	12.7	482.6	15.1	477.8	20.6	466.8
24"	24.000"	.218"	23.564"	.250"	23.500"	.375"	23.250"	.500"	23.000"	.687"	22.626"	.968"	22.064"
mm	609.6	5.5	598.5	6.4	596.9	9.5	590.6	12.7	584.2	14.3	574.7	24.6	560.4
30"	30.000"	.250"	29.500"	.312"	29.376"	.500"	29.000"	.625"	28.750"				
mm	762.0	6.4	749.3	7.9	746.2	12.7	736.6	15.9	730.3				
32"	32.000"			.312"	31.376"	.500"	31.000"	.625"	30.750"	.687"	30.626"		
mm	812.8			7.9	797.0	12.7	787.4	15.9	781.1	14.3	777.9		
34"	34.000"			.312"	33.376"	.500"	32.700"	.625"	29.500"	.687"	32.626"		
mm	863.6			7.9	847.8			15.9	749.2	14.3	749.2		
36"	36.000"			.312"	35.376"			.625"	24.750"	.750"	34.500"		
mm	914.4			7.9	898.6			15.9	628.7	19.1	876.3		

Size	O.D.	Schedule											
		80 (XS-S)		100		120		140		160		XX	
		Wall	I.D.	Wall	I.D.	Wall	I.D.	Wall	I.D.	Wall	I.D.	Wall	I.D.
1"	1.315"	.179"	.957"							.250"	.815"	.358"	.599"
mm	33.4	4.5	24.3							6.4	20.7	9.1	15.2
1-1/4"	1.660"	.191"	1.278"							.250"	1.160"	.382"	.896"
mm	42.2	4.9	32.5							6.4	29.5	9.7	
1-1/2"	1.900"	.200"	1.500"							.281"	1.338"	.400"	1.100"
mm	48.3	5.1	38.1							7.1	34.0	10.2	27.9
2"	2.375"	.218"	1.939"							.344"	1.687"	.436"	1.503"
mm	60.3	5.5	49.3							8.7	42.8	11.1	38.2
2-1/2"	2.875"	.276"	2.323"							.375"	2.125"	.552"	1.771"
mm	73.0	7.0	59.0							9.5	54.0	14.0	45.0
3"	3.500"	.300"	2.900"							.438"	2.624"	.600"	2.300"
mm	88.9	7.62	73.7							12.3	66.6	15.2	58.4
4"	4.500"	.337"	3.826"			.438"	3.624"			.531"	3.438"	.674"	3.152"
mm	114.3	8.6	97.2			11.1	92.0			13.5	87.3	17.1	80.1
5"	5.563"	.375"	4.813"			.500"	4.563"			.625"	4.313"	.750"	4.063
mm	141.3	9.5	122.3			12.7	115.9			15.9	109.6	19.1	103.2
6"	6.625"	.423"	5.761"			.562"	5.501"			.719"	5.187"	.864"	4.897"
mm	168.3	10.7	146.3			14.3	139.7			18.3	131.7	21.9	124.4
8"	8.625"	.500"	7.625"	.594"	7.437"	.719"	7.187"	.812"	7.001"	.906"	6.183"	.875"	6.875"
mm	219.1	12.7	193.7	15.1	188.9	18.3	182.5	20.6	177.8	23.0	157.0	22.2	174.6
10"	10.750"	.594"	9.562"	.719"	9.312"	.844"	9.062"	1.000"	8.750"	1.125"	8.500"		
mm	273.1	15.1	14.3	18.3	236.5	21.4	230.2	25.4	222.3	28.6	215.9		
12"	12.750"	.688"	11.374"	.844"	11.062"	1.000"	10.750"	1.125"	10.500"	1.312"	10.126"	1.000"	10.750"
mm	323.9	17.5	288.9	21.4	281.0	25.4	273.1	28.6	266.7	33.3	252.2	25.4	273.1
14"	14.000"	.750"	12.500"	.938"	12.124"	1.094"	11.812"	1.250"	11.500"	1.406"	11.188"		
mm	355.6	19.1	317.5	23.8	307.9	27.8	300.0	31.8	292.1	35.7	284.2		
16"	16.000"	.844"	14.312"	1.031"	13.938"	1.219"	1.562"	1.438"	13.124"	1.594"	12.812"		
mm	406.4	21.4	363.5	26.2	354.0	31.0	39.7	36.5	333.3	40.5	325.4		
18"	18.000"	.938"	16.124"	1.156"	15.688"	1.375"	15.250"	1.562"	14.876"	1.781"	14.438"		
mm	457.2	23.8	409.5	29.4	398.5	34.9	387.4	39.7	377.9	45.2	366.7		
20"	20.000"	1.031"	17.938"	1.281"	17.438"	1.500"	17.000"	1.750"	16.500"	1.969"	16.062"		
mm	508.0	26.2	455.6	32.5	442.9	38.1	431.8	44.5	419.1	50.0	408.0		
24"	24.000"	1.219"	21.562"	1.531"	20.938"	1.812"	20.376"	2.062"	19.876"	2.344"	19.312"		
mm	609.6	31.0	547.7	38.9	531.8	46.0	517.6	52.4	504.9	59.2	490.5		

Common Pipe Wall Thickness Standard — 12" - 48" = .375" (304.8 - 1219.2 = 12.7) X-Heavy — 8" - 48" = .500" (203.2 - 1219.2 = 12.7)

Standard AFC and BFC Tooling**

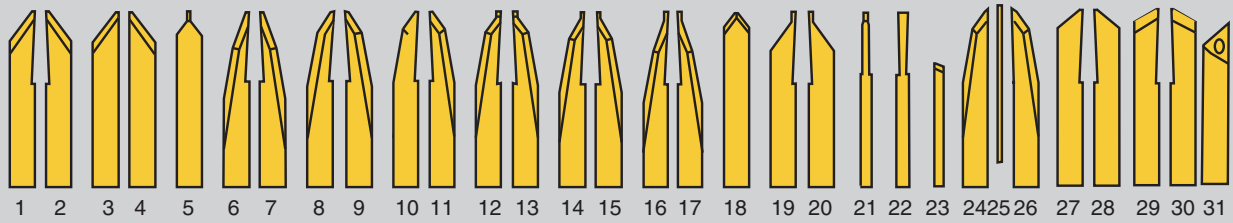

Item Part No. Description

1	220-1013	37° R.H. Bevel, 7"
	220-1064	37° R.H. Bevel, 3.5"
2	220-1014	37° L.H. Bevel, 7"
	220-1061	37° L.H. Bevel, 3.5"
3*	220-1016	37° R.H. Double Bevel, 7"
	220-1077	37° R.H. Double Bevel, 3.5"
4*	220-1015	37° L.H. Double Bevel, 7"
	220-1078	37° L.H. Double Bevel, 3.5"
5	220-1080	37° Double Bevel Sever, 7"
	220-1020	37° Double Bevel Sever, 3.5"
6	220-1025	20° - 10° R.H. Bevel, 7"
7	220-1023	20° - 10° L.H. Bevel, 7"
8	220-1029	30° - 10° R.H. Bevel, 7"
9	220-1027	30° - 10° L.H. Bevel, 7"
10	220-1009	37° - 10° R.H. Bevel, 7"
11	220-1012	37° - 10° L.H. Bevel, 7"
12	220-1010	37° - 10° R.H. Sever, 7"
13	220-1011	37° - 10° L.H. Sever, 7"
14	220-1028	30° - 10° R.H. Sever, 7"
15	220-1026	30° - 10° L.H. Sever, 7"
16	220-1024	20° - 10° R.H. Sever, 7"
17	220-1022	20° - 10° L.H. Sever, 7"

Item Part No. Description

18	220-1079	37° Double Bevel, 7"
	220-1019	37° Double Bevel, 3.5"
19	220-1063	37° R.H. Sever, 7"
	220-1062	37° R.H. Sever, 3.5"
20	220-1060	37° L.H. Sever, 7"
	220-1059	37° L.H. Sever, 3.5"
21	220-1002	1/4" Sever, 7"
	220-1041	1/4" Sever, 3.5"
22	220-1001	3/8" Sever, 7"
	220-1042	3/8" Sever, 3.5"
23	220-1081	10° Counter Bore, 2"
24*	220-1018	37° - 10° R.H. Double Bevel, 7"
25*	220-1248	1/8" Sever, 6"
26*	220-1017	37° - 10° L.H. Double Bevel, 7"
27	220-1225	45° R.H. Bevel, 7"
	220-1223	45° R.H. Bevel, 3.5"
28	220-1226	45° L.H. Bevel, 7"
	220-1224	45° L.H. Bevel, 3.5"
29	220-1129	30° R.H. Bevel, 7"
	220-1099	30° R.H. Bevel, 3.5"
30	220-1131	30° L.H. Bevel, 7"
	220-1125	30° L.H. Bevel, 3.5"
31	220-1308	Counterbore Insert Holder
	INS38N	Carbide Insert

* Blades used as a set.

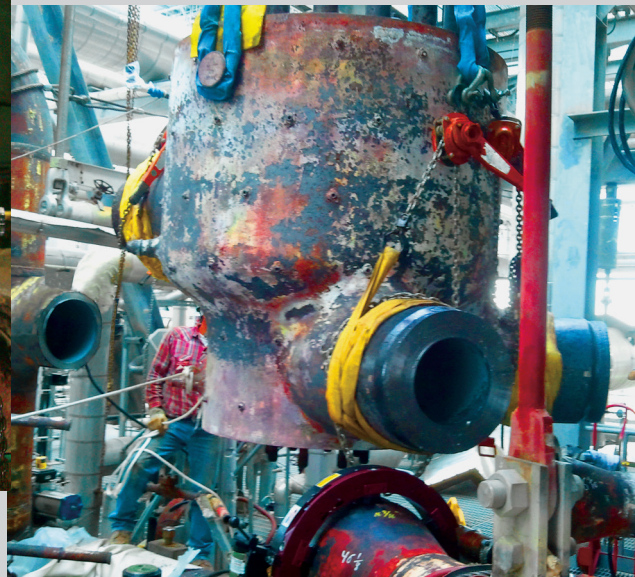

Accessories

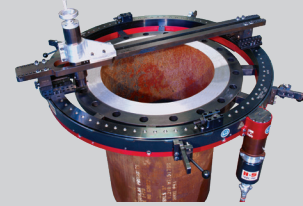
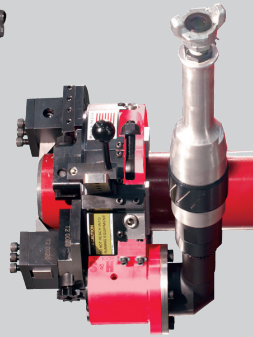
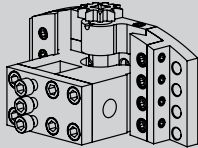
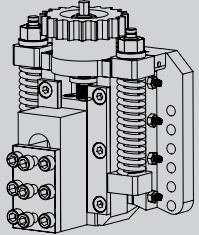
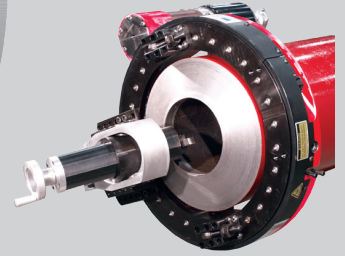
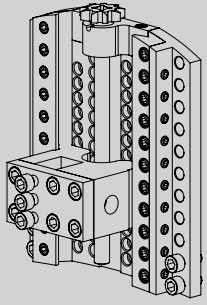

Tool Slides

The H&S tool slides are ruggedly built for strength and durability. Four cap screws are all that are required to securely mount the slides. This dramatically speeds and eases tool slide mounting and locating. Standard sizes are 1", 2", 3", 4", 7" and 10". Other sizes are available. Out-of-round and axial-feed tool slides are also available.



Machining Tools

Call them blades, bits, cutters or cutting tools, H&S offers a full selection of standard cutters. Custom designs are also produced to satisfy every need.



Motor Adapters

Adapters are available to mount the motor out the front or at a right angle to the frame for work in congested areas. The patent pending H&S motor adapters eliminate the need for additional motors and conversion components.

Counter Bore Heads

Perform precision counter bores with fixed or swivel counter bore head designs. These are also mounted directly on tool holders or on a cross bar attachment to accurately refinish flanges from 4" to 86" O.D. (101.6 to 2184.4 mm) with surface finishes from 63 to 500 RMS.



H&S Tool is ready to assist you in whatever you need to improve the productivity and accuracy of your pipe machining projects. Supported by the latest in computer-aided design and production equipment, we will quote you on anything from custom size tool slides to other specialty machines. Contact us or your representative with your specific requirements.

H&S TOOL
A CLIMAX COMPANY

P.O. Box 393 • Wadsworth, OH 44282 U.S.A.
Tel: +1-330-336-4550 • Fax: +1-330-336-9159
www.hstool.com • www.multiprep.com • email: info@hstool.com